

Type: Semi-hermetic twin screw compressors

Producer: Frascold

Series: R-TSH

Model: R-TSH8-60 186 Y

Technical data

Nominal motor power [kW/HP]:	44,5 / 60
Displacement [m ³ /h]:	186
Capacity control [%]:	100 - 50
RPM [min ⁻¹]:	2960
Weight net [kg]:	250
Weight gross [kg]:	275

Electrical data

	<u>PWS</u>
Power supply [V/~/Hz]:	400/3/50
Locked rotor current [A]:	243
Locked rotor current (D.O.L. - ΔΔ) [A]:	399
Max. operating current [A]:	108
Max. power input [kW]:	65

Connections

	<u>milimeters</u>	<u>inches</u>
Suction line:	80	3 1/8
Discharge line:	54	2 1/8

R22

Cooling capacity [W]

$t_c \setminus t_e$	12.5	10	5	0	-5	-10	-15	-20
30	-	227 940	193 250	162 800	136 220	113 100	93 070	75 820
40	224 920	207 370	175 410	147 370	122 920	101 660	83 270	37 450
50	202 110	185 860	156 280	130 360	107 770	88 160	71 220	56 670
55	191 380	175 830	147 550	122 780	101 210	82 490	66 340	52 480

Power input [kW]

$t_c \setminus t_e$	12.5	10	5	0	-5	-10	-15	-20
30	-	37.43	36.76	35.52	34.06	32.48	31.08	30.16
40	45.17	44.76	43.38	41.62	39.82	38.09	36.80	36.40
50	53.99	53.34	51.59	49.55	47.55	45.65	44.40	44.48
55	63.64	62.32	59.55	56.81	54.41	52.51	51.72	53.18

Current [A]

$t_c \setminus t_e$	12.5	10	5	0	-5	-10	-15	-20
30	-	666.70	65.80	64.20	62.20	60.10	58.30	57.00
40	77.40	76.90	74.90	72.50	70.00	67.60	65.90	65.30
50	90.60	89.60	86.90	83.80	80.80	78.10	76.40	76.50
55	106.40	104.10	99.60	95.10	91.30	88.30	87.10	89.40

Mass flow [kg/h]

$t_c \setminus t_e$	12.5	10	5	0	-5	-10	-15	-20
30	-	4 541	3 892	3 317	2 809	2 362	1 970	1 627
40	4 801	4 451	3 810	3 241	2 739	2 296	1 908	1 569
50	4 694	4 343	3 699	3 127	2 623	2 178	1 787	1 446
55	4 660	4 309	3 665	3 093	2 589	2 144	1 753	1 411

Operating conditions: suction gas overheating 10K, 0K subcooling

Application limits

Full load operation

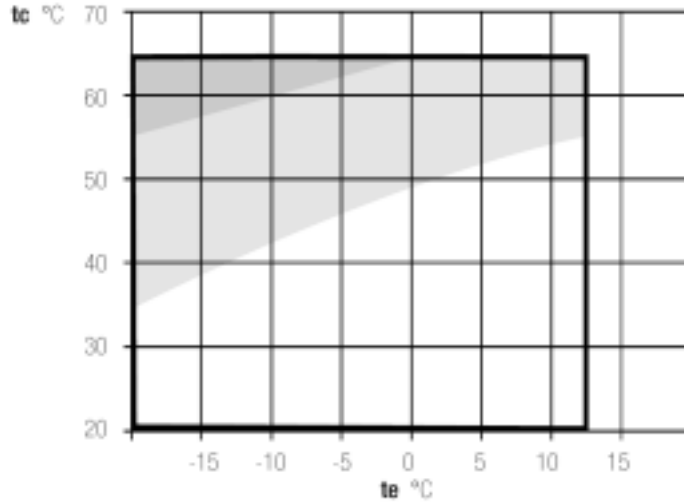

Capacity control

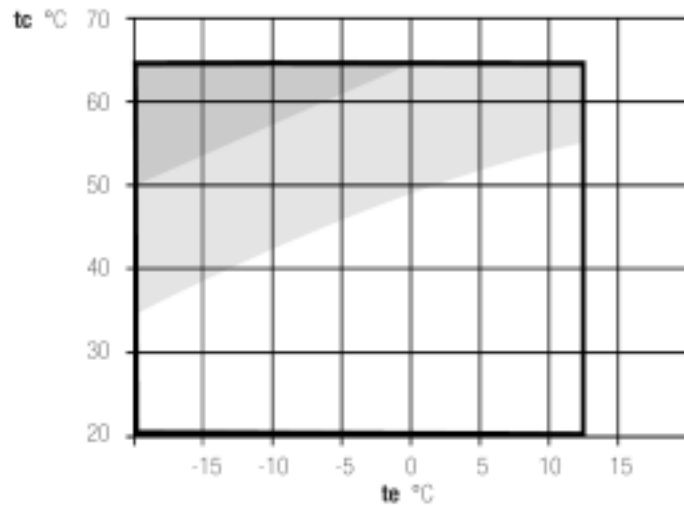

- With oil cooler
- With liquid injection and oil cooler

t_c - Condensing temperature [°C]
 t_e - Evaporating temperature [°C]

R134a

Cooling capacity [W]

$t_c \setminus t_e$	20	15	10	5	0	-5	-10
30	-	-	-	-	106 570	86 750	69 950
40	-	168 640	140 110	115 500	94 350	76 330	61 080
50	178 080	148 260	122 470	100 260	81 230	65 040	51 390
55	153 670	125 910	101 980	81 440	63 920	49 080	36 630

Power input [kW]

$t_c \setminus t_e$	20	15	10	5	0	-5	-10
30	-	-	-	-	22.10	21.26	20.43
40	-	29.59	28.55	27.37	26.24	25.33	24.82
50	36.20	35.40	34.21	32.88	31.63	30.66	30.23
55	44.29	42.38	40.31	38.39	36.88	36.21	37.34

Current [A]

$t_c \setminus t_e$	20	15	10	5	0	-5	-10
30	-	-	-	-	45.80	44.70	43.60
40	-	56.30	55.00	53.40	51.80	50.40	49.60
50	65.10	64.00	62.40	60.60	59.00	57.70	57.20
55	76.20	73.50	70.70	68.10	66.00	65.10	66.60

Mass flow [kg/h]

$t_c \setminus t_e$	20	15	10	5	0	-5	-10
30	-	-	-	-	2 314	1 920	1 578
40	-	3 789	3 208	2 697	2 249	1 858	1 519
50	4 335	3 682	3 106	2 599	2 154	1 766	1 429
55	4 194	3 515	2 914	2 386	1 922	1 516	1 162

Operating conditions: suction gas overheating 10K, 0K subcooling

Application limits

Full load operation

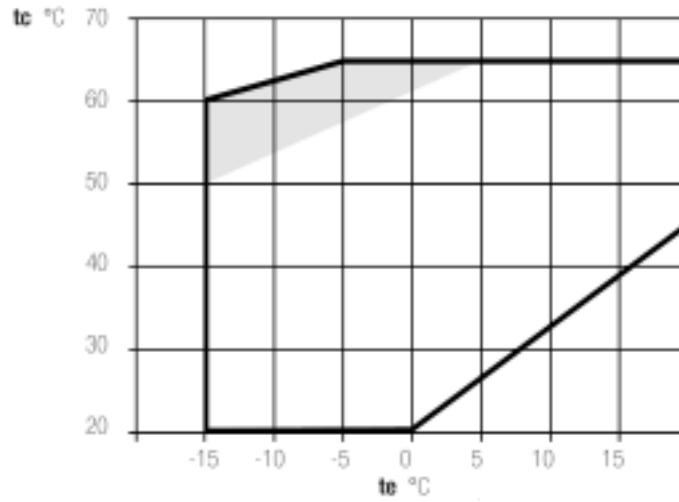

Capacity control

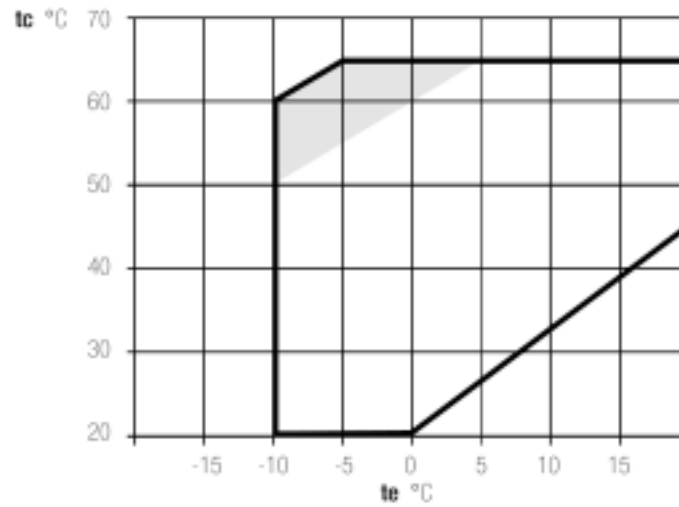

- With oil cooler
- With liquid injection and oil cooler

t_c - Condensing temperature [°C]
 t_e - Evaporating temperature [°C]

R404A/R507

Cooling capacity [W]

$t_c \setminus t_e$	7.5	5	0	-5	-10	-15	-20
30	227 540	208 080	173 590	143 750	118 590	96 600	77 990
40	193 060	176 030	145 890	119 890	98 010	78 980	62 940
50	155 630	141 090	115 430	93 380	74 910	58 960	45 620
55	138 490	125 220	101 840	81 810	65 090	50 710	38 750

Power input [kW]

$t_c \setminus t_e$	7.5	5	0	-5	-10	-15	-20
30	34.06	35.06	36.40	36.83	36.70	35.94	34.82
40	47.68	47.50	46.69	45.26	43.68	41.85	40.17
50	60.19	59.06	56.58	53.72	50.95	48.13	45.67
55	67.36	65.64	62.19	58.77	55.67	52.73	50.53

Current [A]

$t_c \setminus t_e$	7.5	5	0	-5	-10	-15	-20
30	62.20	63.50	65.40	65.90	65.80	64.70	63.20
40	81.00	80.70	79.60	77.60	75.30	72.80	70.50
50	100.60	98.70	94.70	90.20	85.90	81.60	78.10
55	112.70	109.80	103.90	98.30	93.30	88.70	85.30

Mass flow [kg/h]

$t_c \setminus t_e$	7.5	5	0	-5	-10	-15	-20
30	5 939	5 487	4 677	3 962	3 347	2 795	2 316
40	5 724	5 280	4 485	3 782	3 178	2 635	2 164
50	5 451	5 010	4 219	3 520	2 919	2 378	1 908
55	5 381	4 940	4 149	3 450	2 848	2 307	1 837

Operating conditions: suction gas overheating 10K, 0K subcooling

Application limits

Full load operation

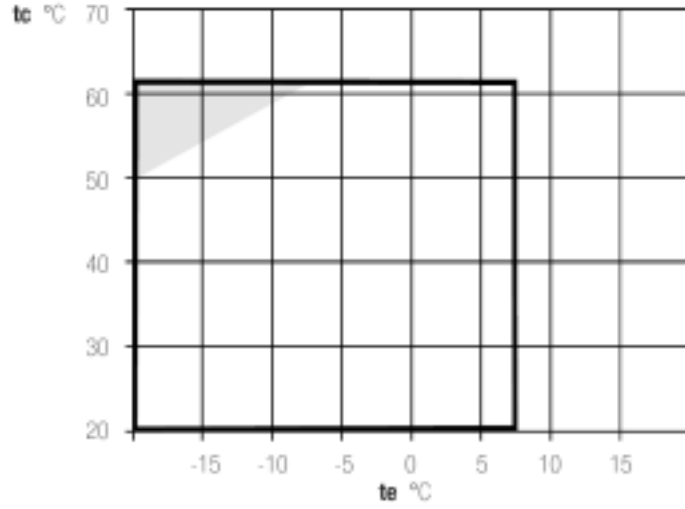

Capacity control

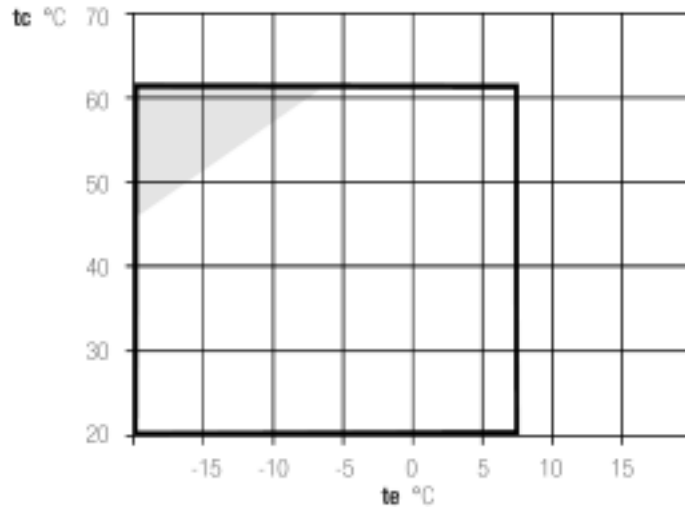

- With oil cooler
- With liquid injection and oil cooler

t_c - Condensing temperature [°C]

t_e - Evaporating temperature [°C]

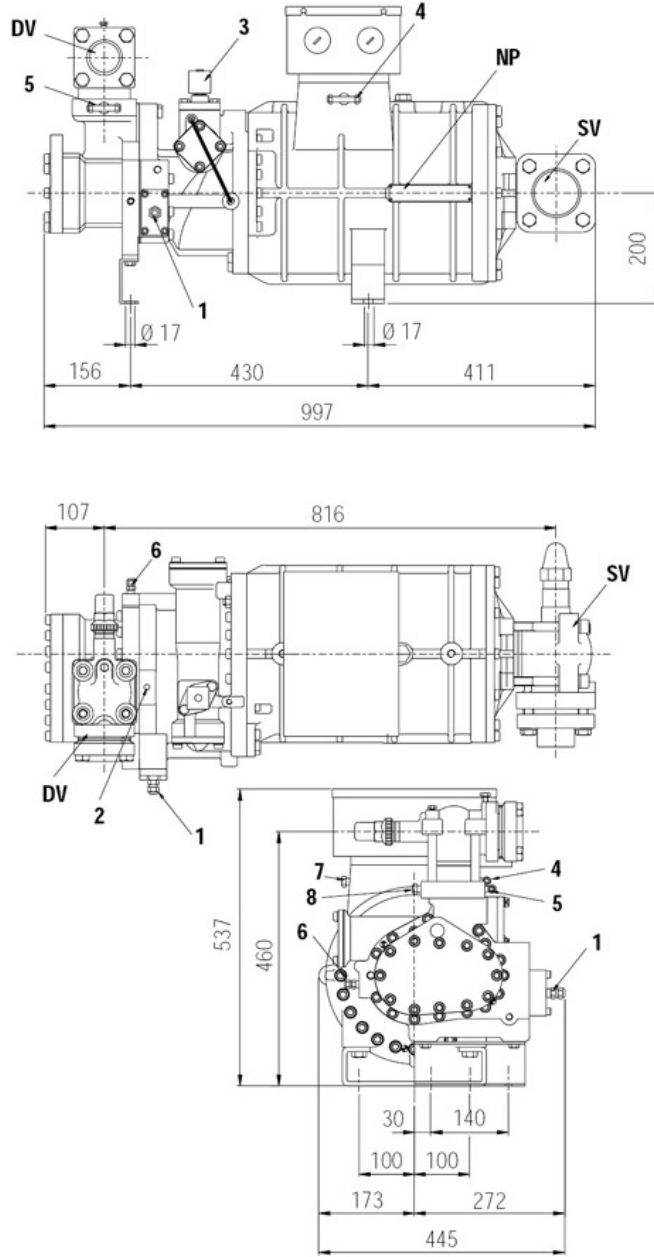

1: connection of oil return valve
 3: capacity control valve
 5: high pressure plug
 7: plug for low pressure connection
 DV: discharge valve
 SV: suction valve

2: max. discharge temperature sensor
 4: low pressure plug
 6: liquid injection/economizer conn.
 8: plug for high pressure connection
 NP: name plate

